

# Banding machine VBM 50 / BM 25

Banding machine for flat products up to format width 300 x 210 and 45 mm package height

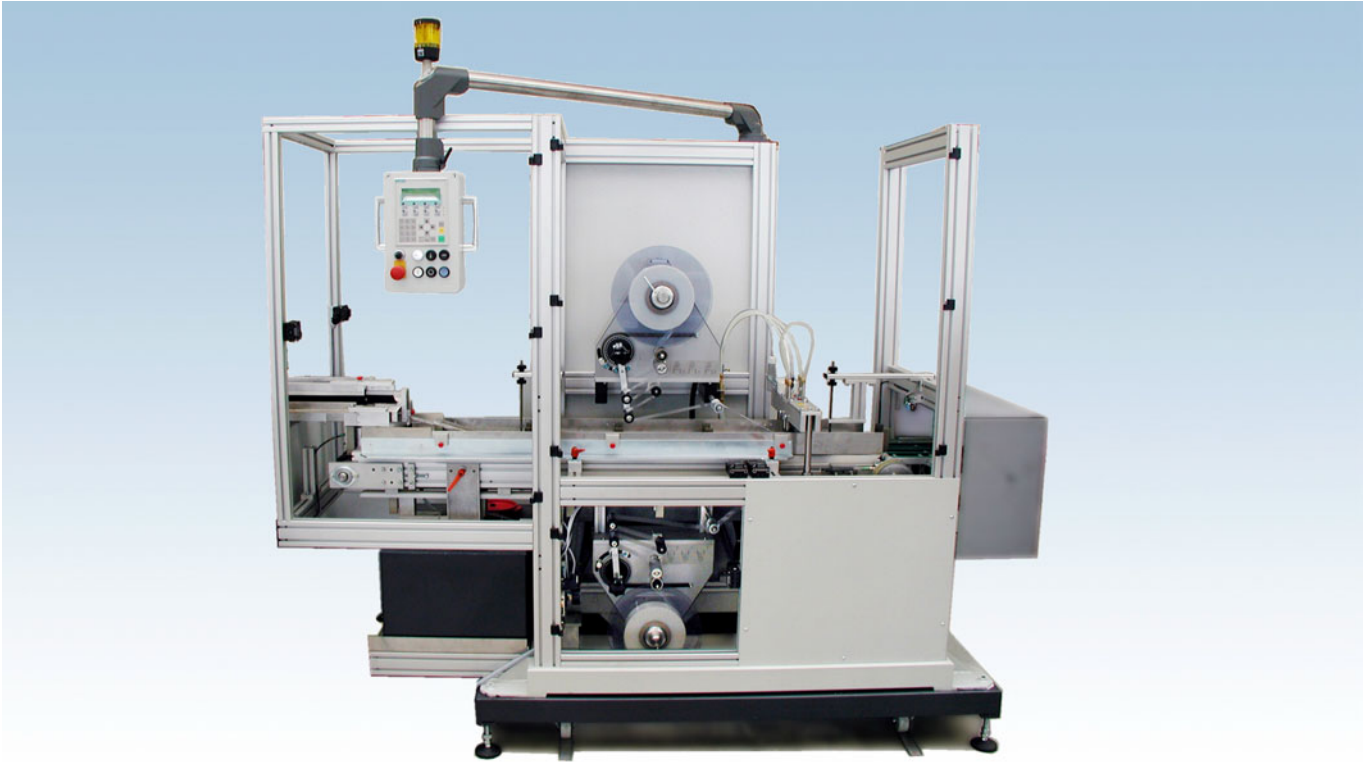

## Applications:

- Paper products like envelopes, letters (filled), post cards, greeting cards, folding boxes, and the like
- Flat products, like blister packs, compresses, sachets, chip cards, Booklet strip, pencils, measuring sticks, and the like
- Format width up to a maximum of 300 x 210 mm and a package height of up to 45 mm.

## Types of wrapping:

- Sealed film sleeve with 30 and 50 mm film width (Option)

## Function:

- Counting and infeed in the stacking magazine of the flighted belt conveyor by means of an infeed unit.
- Cycled feed of the counted product stack to the sealing knife.
- Sealing of the upper and lower film by means of the sealing unit.
- Transfer to the follow-up machine with integrated outfeed conveyor.
- Water-cooled holding-down devices for permanently good sealing quality.
- Powered sealing unit at VBM 50 machine type.  
Pneumatical sealing unit at BM 25 machine type.
- Economical use of the banding film caused by thin PE film with 30 µm.
- Powered film rewinding with spring tension.

## Programmable Logic Control:

- Operator guidance and status display by 4-line LC display
- Editing and input keys for entering values into operator menus or for acknowledging messages
- Operating keys for START, STOP, RESET and EMERGENCY STOP
- Operating mode CYCLE and AUTO
- Display or modification of operating parameters
- Choice of 2 operator languages
- Status diagnosis and fault messages
- Fault message indication by way of signal lamp and plain text message
- Electric and electronic plug-type connections.

Technical data:	
	<b>VBM 50 / BM 25</b>
<b>Format range: Product height:</b>	Min. 100 x 50 mm, Max. 300 x 210 mm Min. 2 mm, Max. 45 mm
<b>Cycle speed (depending on the product)</b>	Max. 50 packages/min. (VBM 50) Max. 25 packages/min. (BM 25)
<b>Wrapping film:</b>	Polypropylene (BOPP/PP), film thickness 15 up to 30 µm, Polyethylen (PE), film thickness 30 µm - 60 µm, film thickness 30 and 50 mm (Option)
<b>Drive:</b>	Servo geared motor, infinitely variable
<b>Control:</b>	PLC control SIEMENS S7 with control panel OP 7
<b>Supply voltage: Power input:</b>	3 x 400 V / 50 Hz, approx. 3 kVA, (10 nominal current)
<b>Compressed-air connection</b>	6 bar dry, oil-free air, connection ¼", air consumption max. 50 l/min.
<b>Dimensions (W x D x H) / Weight:</b>	2.300 x 1.050 x 1.850 mm (standard configuration)/ approx. 600 kg, according to machine equipment

### Layout Standard configuration:

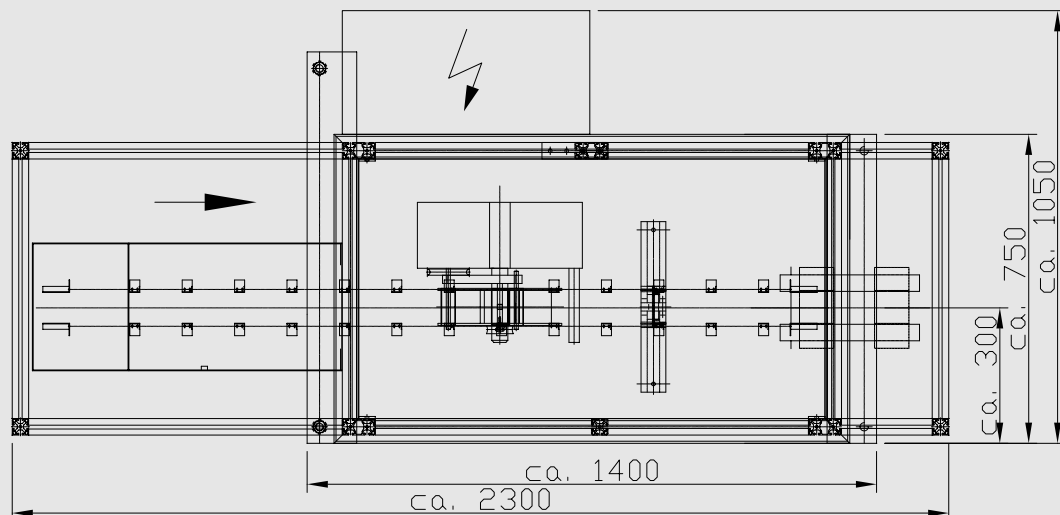

### Options:

<b>Film width 50 mm</b>	<ul style="list-style-type: none"> <li>• On request</li> </ul>	<b>Lifting / turning station at transport conveyor</b>	<ul style="list-style-type: none"> <li>• For turning over the packages after sealing</li> </ul>
<b>Infeed unit:</b>	<ul style="list-style-type: none"> <li>• For link to packaging machines to count and stack into the infeed of the VBM 50 / BM 25</li> </ul>	<b>Shingling outfeed conveyor</b>	<ul style="list-style-type: none"> <li>• With attachment in longitudinal or transversal direction to the VBM 50 / BM 25</li> </ul>
<b>Adjustable infeed stopper:</b>	<ul style="list-style-type: none"> <li>• For individual adaption to preceding machine / infeed length</li> </ul>	<b>Special accessories:</b>	
<b>Outfeed conveyor:</b>	<ul style="list-style-type: none"> <li>• Special length on request</li> </ul>	<b>Scanner / Camera:</b>	<ul style="list-style-type: none"> <li>• For registration of barcodes and consecutively numbered products (e.g. banknotes)</li> </ul>
<b>Feeder on transport conveyor, incl. Prolonged transport conveyor:</b>	<ul style="list-style-type: none"> <li>• Inline, with direct feed into the flighted belt conveyor</li> <li>• Mounted in transversal position to the conveyor, with direct feed into the conveyor</li> </ul>	<b>Labelling device:</b>	<ul style="list-style-type: none"> <li>• For labelling of the sealed packages in the outfeed</li> <li>• Different solutions on request</li> </ul>
<b>Frame with prolonged transport conveyor:</b>	<ul style="list-style-type: none"> <li>• With equipment of feeders, labellers, scanners and other accessories on the transport conveyor</li> </ul>	<b>Special solutions:</b>	<ul style="list-style-type: none"> <li>• On request</li> </ul>
<b>Transport belt with customized separation:</b>	<ul style="list-style-type: none"> <li>• Adaption of the transport belt to product width</li> </ul>		
<b>Transport belt with central adjustment</b>	<ul style="list-style-type: none"> <li>• For fast adjustment of the guide bars to new product formats</li> </ul>		
<b>Package height up to 60 mm:</b>	<ul style="list-style-type: none"> <li>• For packages higher than 20 mm</li> </ul>		
<b>Outfeed conveyor:</b>	<ul style="list-style-type: none"> <li>• With round belts</li> </ul>		

*Subject to technical modifications*