

FP-W100



- Overwrapping with 3-sided sealing seam
- Safe, precise and narrow overwrapping
- Overwrapping of 5 up to 25 phone cards per stack

Design and characteristics:

- Clearly arranged and stable machine body with topical design.
- Direct infeed for transfer of the products from the phone card wrapping machine.
- Servo drives for optimized velocity synchronization to the phone card wrapping machine.
- Flexible adjustment of the package sizes, depending on the phone card wrapping machine.
- Fast and easy card format changes.
- Overwrapping of single cards and bag chains.
- Simple machine operation by means of a graphical user interface and touchscreen.

Options:

- Format part sets
- Tear-off stripe
- Equipment with camera and data processing
- Labelling device or hot foil printer for marking of the overwrap package.
- Outfeed conveyor

Technical Data:

	FP-W100
Format range/ Performance (depending on product):	85 x 54 mm (CR-80/ISO 7810), Produkt thickness 0.25 – 0.8 mm Up to 50 cycles / minute
Package height (depending on product):	Min. 5 mm, max. 30 mm (non-compressed stack)
Film material:	See separate specification, 35 µm
Film roll size:	Flat film: Inner diameter 76 mm, max. external diameter 350 mm, Width 160 up to 250 mm (depending on package height)
Main drive:	Servo drive, infinitely variable
Sealing procedure:	Thermal Sealing
Control unit:	Programmable Logic Control (PLC) with touchscreen
Power supply:	3 x 400 V / 50 Hz /N /PE
Power consumption:	Approx. 5 kW
Pressure air supply:	6 bar, dry and oil-free approx. 100 l/h.
Dimensions (W x D x H):	Approx. 2.800 x 1.000 x 1.700 mm (Standard machine) Approx. 4.800 x 1.000 x 1.700 mm (with outfeed belt, option)
Weight:	Approx. 700 kg (With cycled conveyor und upper carrier chain)

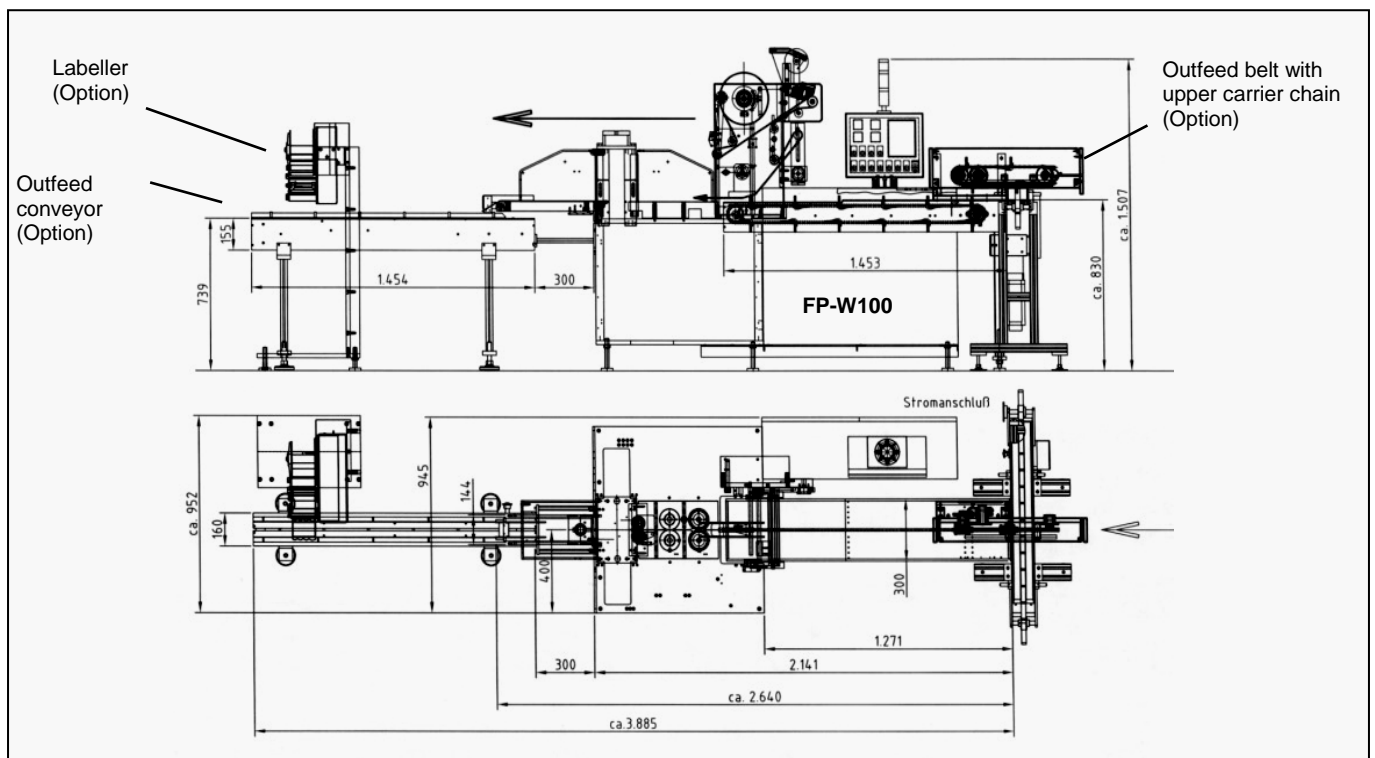

KÖRA-PACKMAT Maschinenbau GmbH
 Gewerbestrasse 4
 D-78667 Villingendorf
 Germany
 Phone: + 49 741 92830
 Fax: + 49 741 928330
 sales@koera-packmat.de
 www.koera-packmat.de