

Application

The universal feeder for catalogue and brochure assortments (in foil wrapping or in envelope), in middle performance range.
 Integration in commissioning plants in warehouse sector

Technical data		Products	
Performance (depending on product)	100 m/min max. 180 Cycles/min	Format	min. 90 x 90 mm max. 310 x 320 mm
Power supply	230 V / 50 Hz, 300 VA	Product weight	min. 80 g/m ² / single sheet
Control unit	Microprocessor, PLC interface 15-pins	Package height	0,1 – 12 mm

Standard Characteristics

- Feeding width 350 mm Standard
- Horizontal conveyor magazine: 2000 mm
- Single feeding, counting and with pulse generator
- Vacuum chamber with perforated friction belts and ejector / vacuum pump
- Quick setting of the product width (air gap), repeatable, analog display
- Repeatable setting by means of scales at all setting points
- Exit extension swiveling 0° bis - 20°, 300 mm length
- DC Motor, infinitely variable
- Microprocessor control unit with PLC interface
- Signal lamp single-color
- Missing sheet control by monitoring of product runtime
- Minimum stack monitoring in horizontal magazine

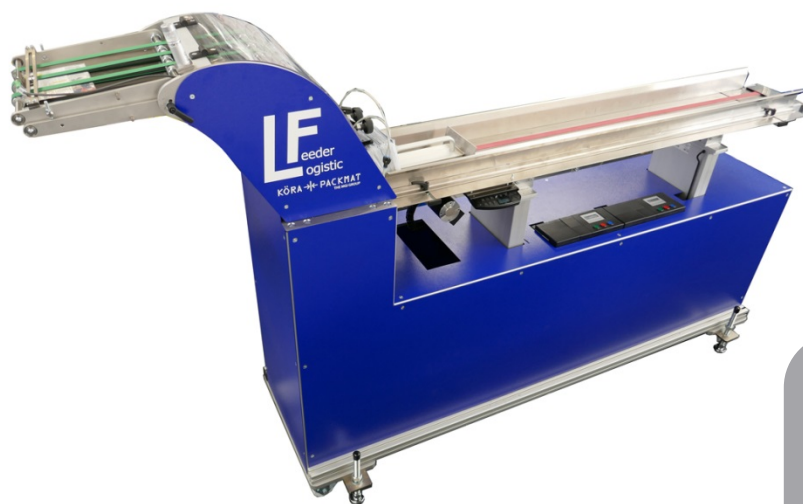

Further options see backside

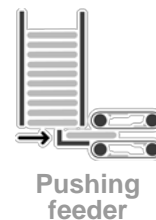
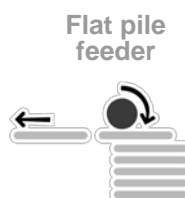
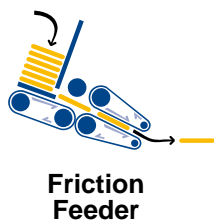

Technical data (Standard configuration)

Format range (special formats possible):	min. 90 x 90 mm, max. 350 x 320 mm (short side leading)
Velocity / Feeding performance (depending on product):	max. 100 m/min max. 180 Products/min (cycled)
Product thickness (depending on product):	min. 0,1 mm, max. 12 mm, paper weight min. 80 g/m ²
Loading conveyor unit (depending on product):	Standard 2000 mm
Drive:	DC Motor, infinitely variable
Control unit:	Microprocessor control etana; PLC interface 15 pins; counter function; daily counter; pulse generator; continuous operation; Protection type IP40; 4-line LC Display; functions and display for self-monitoring, error messages, parameter selection, product length setting for missing and double sheet control, operator language selectable (D, GB, F Standard), etc.
Power supply / Power consumption:	230 V / 50 Hz, 300 VA
Pressure air supply:	6 bar dry, oil-free air, connection ¼ ", air consumption 100 l/min (w. 2 vacuum chambers)
Dimensions (W x D x H) / Weight:	2540 x 656 x 1540 mm (standard version), approx. 260 kg, (configuration acc. to layout)
Noise level (w. 2 vacuum chambers)	Max. 70 dB (A), with pressure air 6 bar

Dimensions

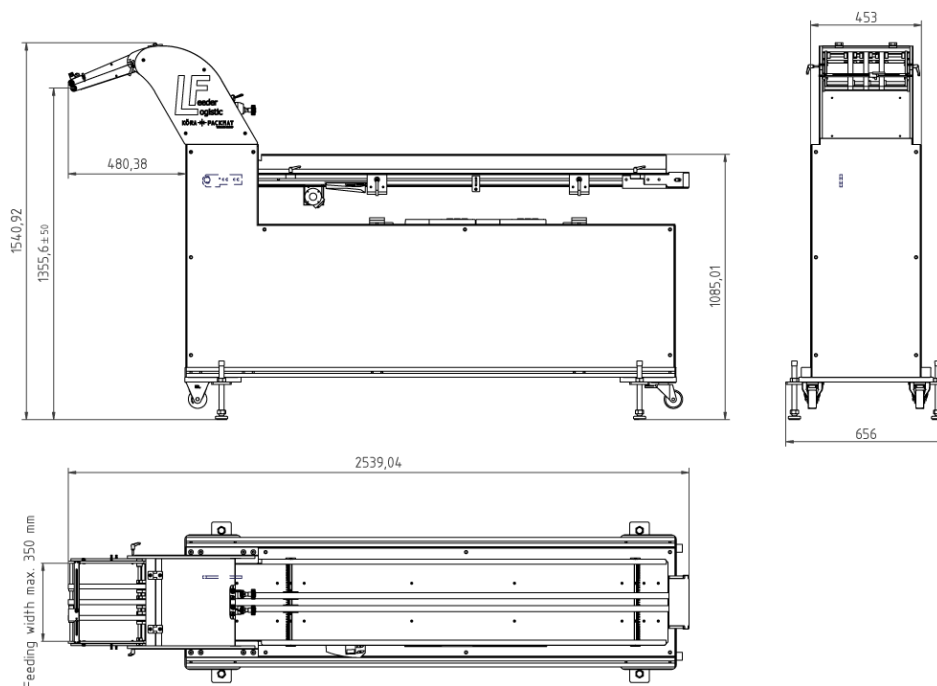

Options (depending on product)

Magazine / Loading

Magazine length 3.000 / 4.000 mm

Control / Monitoring

Signal lamp up to 3 colors

Level control in horizontal magazine

Integration of peripheral devices

Depending on customer application

Separation

Antistatic unit for foil separation

Transport / Material handling

Feeding tray, adjustable for different formats

Exit options

Exit extension 500/800 mm

Miscellaneous

div. pedestals: movable, with height setting

Wear parts kit

Special versions on request

Start sensor

