

Complete solution for various product marking

Design and characteristic features:

- Feeding and labelling of packing material like e.g. folding cardboard boxes or diverse flat products
- Integration of various components like e.g.:
 - Labelling unit
 - ink-jet systems
 - drag mark detectors and others
- Base material supply via feeder (inline or at an angle of 90° to the line)
- Continuously running flighted belt conveyor for the transport through the test and marking stations
- Quickly running transfer belt for hand-over to the stacking module or following processing machine

- PLC interface, 15 pin
- Operator guidance and status indication by LC display
- Preselection for piece number with NOM/ACT comparison
- Fault message indication by way of signal lamp and display
- Selectable operator language in German, English or French
- Electric and electronic plug-type connections
- Own microprocessor control for transport conveyor, shingled outfeed conveyor and transfer station
- Level detection in the feeder magazine and in the stacking magazine

Options:

- Tacho-generator control for external synchronization of the conveyor speed
- Parameter setting via external PLC (number of pieces, start signal, etc.)

Control Unit:

Format range (special formats possible):	Min. 150 x 100 mm, max. 400 x 450
Speed (depending on product):	Max. 100 cycles/min.
Product passage:	Min. 1 mm, max. 30 mm
Magazine loading (depending on product):	Feeder: Standard 580 mm, option 800 mm / 1,000 mm piling conveyor 2,000 mm long, usable width approx. 450 mm
Drive:	DC servo-motors, infinitely controllable stepper motors for conveyor belts
Control:	Microprocessor control, PLC interface, functions for no. of pieces, continuous mode, self-diagnosis, fault message etc. own control for transport conveyor and shingled outfeed conveyor
Supply voltage:	400 V / 50 Hz
Compressed-air connection	6 bar dry, oil-free air, connection ¼ " depending on the feeder design
Dimensions (W x D x H) / Weight:	Approx. 4,000 x 430 x 1,800 mm (design as on layout plan) weight depends on the design

Dimensions complete system:

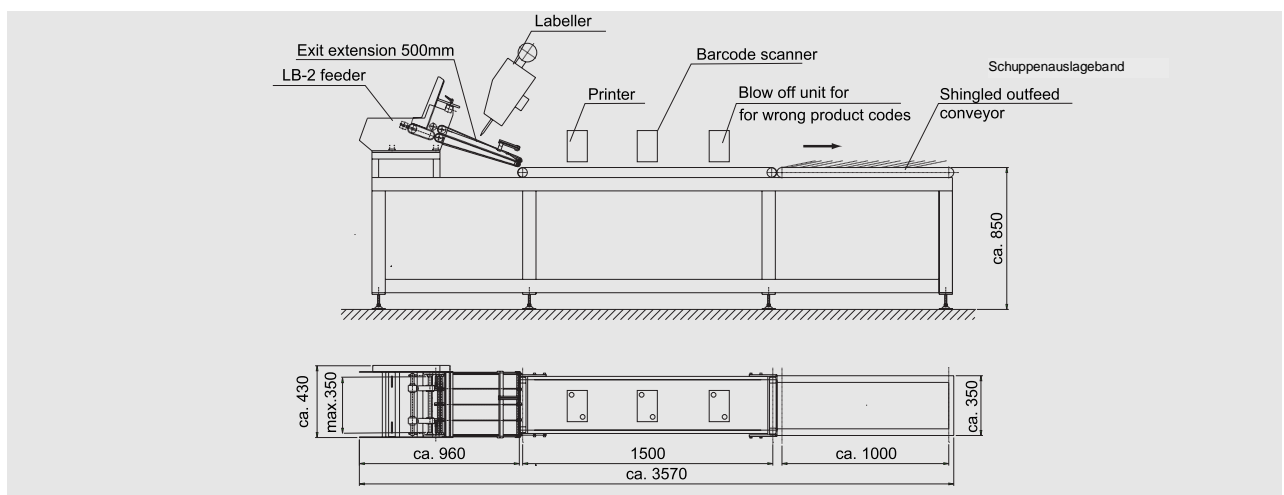

03/2013 Subject to technical modifications

Options:

Options feeder:	Due to data sheet of feeder
Integration of peripheral devices:	Upon request
Stacking tray:	For deposition and manual take-off of the products
Shingled outfeed conveyor:	With preselection and product counter for magazine loading of the products

